



PROPOSED LEASE OF PART OF BUNDOORA PARK FOR THE CONSTRUCTION, OPERATION AND MAINTENANCE OF A TELECOMMUNICATION MONOPOLE

The City of Darebin, acting under section 115 of the *Local Government Act 2020*, proposes to enter into a lease with Amplitel Ltd, for use of part of Bundoora Park, for the purposes on constructing, operating and maintaining a telecommunications monopole.

Council proposes to lease the land under the following key terms and conditions:

- 1) **Term:** 20 years
- 2) **Indicative Commencement Date:** 1 March 2025
- 3) **Lease Area:** Monopole (4500mm x 4500mm) & Equipment cabinet (5000mm x 2500mm)
- 4) **Permitted Use:** Provision of a telecommunication facility including installation, inspection, maintenance, construction, excavation, replacement, repair, renewal, alteration, upgrade, cleaning, operation, access to and from, and removal of facility on the land at the end of the term
- 5) **Commencing rent:** \$27,810 plus GST per annum.
- 6) **Rent review:** Market rent review every three years on the anniversary of the Commencement Date. A fixed increase of 3% in intervening years.
- 7) All maintenance costs are payable by Amplitel, including rates, taxes, and insurance. Each party pays its own legal costs.
- 8) All structural and non-structural maintenance and repairs will be carried out by Amplitel (with exception to the remounted light fittings).
- 9)

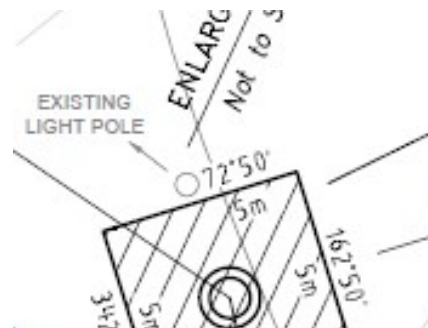
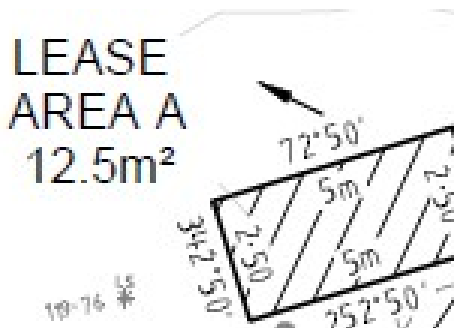

As part of its Community Engagement process Council is inviting submissions on this proposal. Any person wishing to make a submission must do so in writing to the undersigned no later than **5pm Tuesday, 26 November 2024**.

A person making a submission is entitled to request in the submission that they wish to appear in person, or to be represented by a person specified in the submission, in support of the submission at a meeting of the Council or its Committee on a date, time and place to be determined by the Council.

A Hearing of Submissions Committee meeting will be held at 7.30pm on 9 December 2024, if any submitter requests to be heard in person or be represented by a person specified in the submission, in support of their submission.

Written submissions in which the person does not request to be heard in person or be represented by any other person specified in the submission, will be considered at the next available Council meeting, following the closure of submissions.

All submissions will be considered in accordance with the principles noted under section 115 of the *Local Government Act 2020*.

Following the consideration of any submissions, Council may decide to lease the land under the approved terms or seek a variation to the proposal (including its refusal).

Any person making a written submission is advised that all submissions and personal information in the submission will be handled by Council in accordance with the provisions of the *Privacy and Data Protection Act 2014*.

Enquiries to: Council Leasing & Licensing Team on 8470 8888

Submissions should be addressed to the Interim Chief Executive Officer, City of Darebin, PO Box 91, Preston 3072, or delivered to the Municipal Offices, 274 Gower Street, Preston or emailed to LeaseandLicensing@darebin.vic.gov.au

Michael Tudball
Interim Chief Executive Officer